

COMFORT PM



UP 15-14BA PM

The COMFORT range is designed for re-circulation of domestic hot water in one family houses. The COMFORT PM range is the high efficiency choice with an energy usage of only 8 W. The intelligent COMFORT AUTOADAPT PM automatically adapts to the individual hot water consumption pattern in the household and only runs when hot water is needed.

FEATURES

Quiet operation

The low noise permanent magnet motor, at <43dBa the Comfort PM is ultra-quiet.

Reduce wastewater

All COMFORT pumps - with or without the autoadapt function - combined with a return pipe deliver instantly hot water all over the house. This eliminates the expensive and annoying wait for the water to get warm and reduces the annual consumption of domestic water. The results are lower costs while still ensuring the comfort of instant hot water.

Robust design

The pump is made of materials that ensure excellent corrosion resistance. Designed for open systems Comfort PM is constructed from quality brass housing with a high grade composite impeller.

AUTOADAPT

The AUTOADAPT version learns the user pattern of the customer and learns from it. It only runs when hot water is needed.

PERFORMANCE

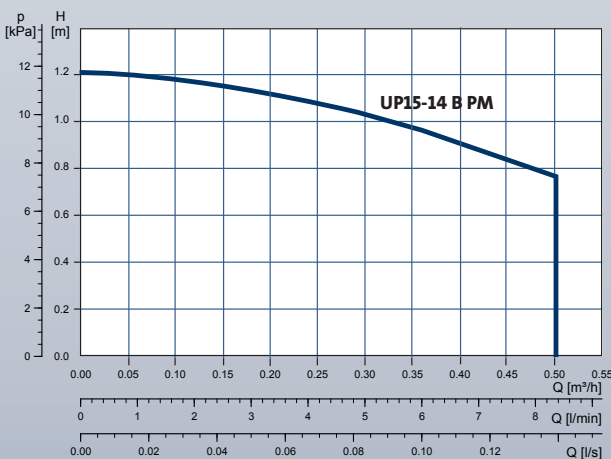

APPLICATIONS

- Domestic hot water circulation

OPERATING CONDITIONS

System pressure

10 bar

Liquid temperature

2 to 110 °C

Ambient temperature

40 °C

Relative air humidity

95 %



TECHNICAL DATA

Mains voltage

1 x 240 V, 50 Hz

Enclosure class

IP44

Insulation class

F

Sound pressure level

43 dB

Approvals and markings

AS4020

DIMENSIONS

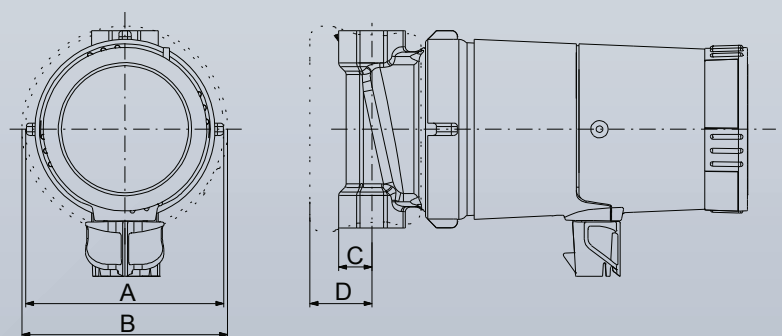

Model	Connection size	Dimensions (mm)				Weight (kg)
		A	B	C	D	
UP15-14B PM	½" F	84	13.5	133	80	1